

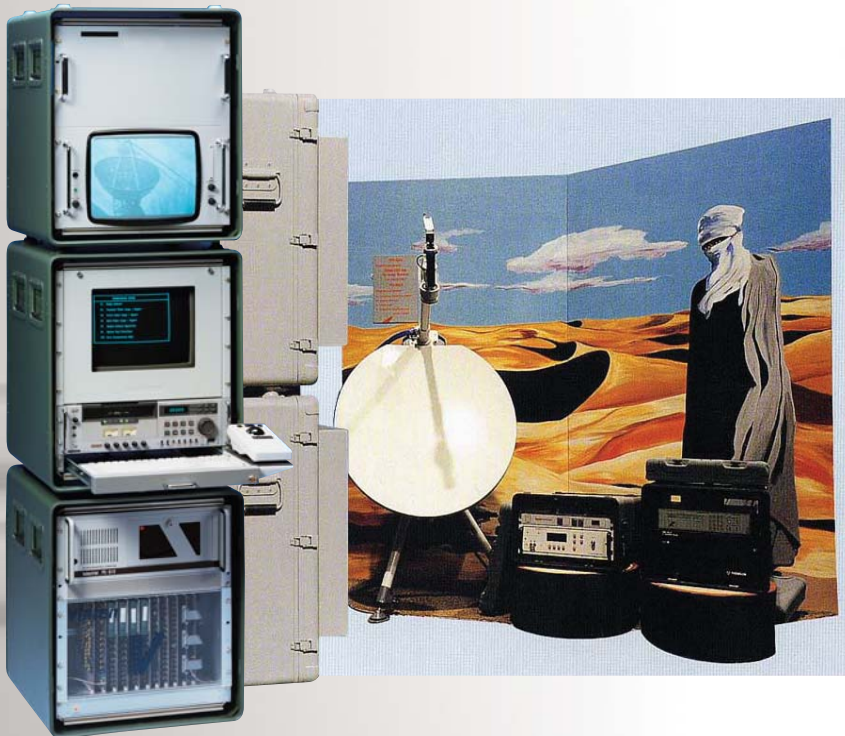

Rugged Protection...

Shock-mounted cases for the protection of 19" electronic equipment in operation or transport.

Zero introduces its range of purpose engineered cases offering maximum protection for delicate 19" equipment against environmental hazards, shock and vibration.



NEWS UPDATE



Patent granted No. GB2395069 for step fronted case to facilitate connectors and cable management

Val-an 700 Series Specification

- Flexibility to custom build to customers needs.
- Short lead times, typically under 4 working weeks from design to delivery, from our Birmingham factory.
- Competitive pricing.
- T-slot and sliding nuts allow exact location of your equipment within the inner frame.
- Strong lightweight aluminium.
- Portable.
- Stackable.
- Wide experience of COTS and DRI4 design.
- Available in 14 standard frame heights from 3U to 16U.
- Available as standard in any depth between 300mm and 809mm.
- Tested to Def-Stan 81-41, level J.
- Meets applicable water sealing and drop requirements of MIL-STD 108 and MIL-T-28800.
- Flexible approach allows you to specify custom modifications to suit your requirements.
- Variety of standard colours and finishes available.
- Flexibility to provide non-standard colours and finishes.
- One-off requirements can be accommodated.
- Cases designed and made in our ISO9001 facility to ensure consistent quality.
- Shock and vibration mounts engineered to suit load and fragility of contained equipment.
- Wide variety of hardware available. Can be surface mounted or recessed.
- EMI/RFI shielding provided if required.

This specification represents the standard format for Zero Val-an 700 Case Series.

We would be happy to discuss any other requirements which you may have which vary in any way from this specification.

Shock-Mounted Cases

(All dimensions in mm)

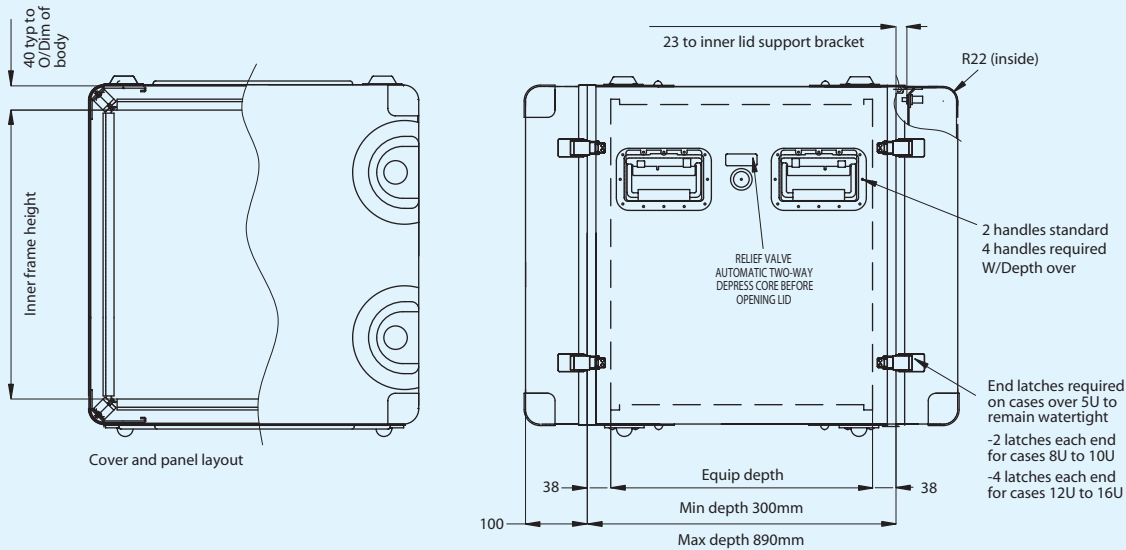

'U' No. Height	Inner Frame Height (mm)	'U' No. Height	Inner Frame Height (mm)
X	Special Size	X	Special Size
3U	135.6	10U	446.8
4U	180.1	11U	491.3
5U	224.6	12U	535.7
6U	269.0	13U	580.2
7U	313.4	14U	624.6
8U	357.9	15U	669.0
9U	402.4	16U	713.5

Accessories

Skirt Seal – To allow for maximum protection of your equipment against water or dust contamination when either cover is removed.

Side Screen – To increase visibility by reducing screen glare.

Cover Supports – Allow case to be operated using the cover as a rain or sun shield.

Inner Lid – Hinged aluminium inner lids with quick release fasteners can be fitted in either cover for cable or accessory stowage.

Pressure Relief Valves – These are available in both Manual and Automatic format. Please specify when ordering.

